

HIGH EFFICIENCY

HEPA

PARTICULATE AIR
MAXX

FILTER
UPGRADE

MAXIMUM AIR PURIFICATION FOR THE TOUGHEST DUST REMOVAL JOBS

BEFORE HEPA

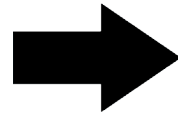
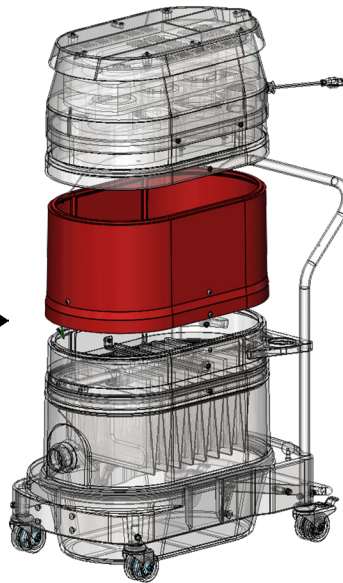
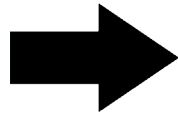
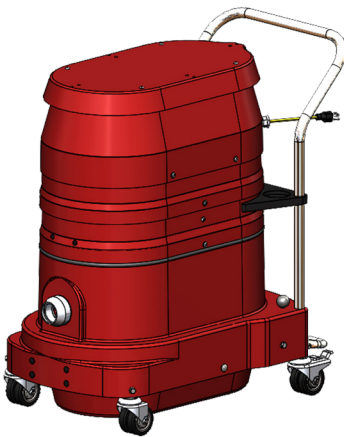

AFTER HEPA

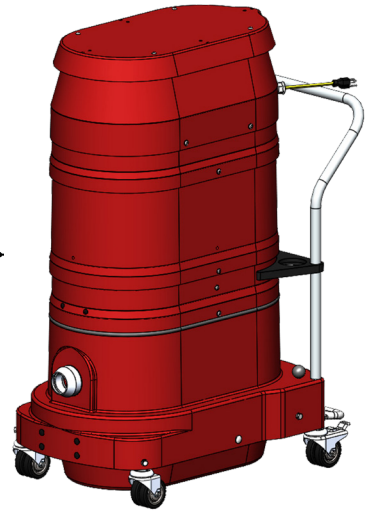

REDUCES COSTLY FILTER REPLACEMENTS

For materials requiring the ultimate level of filtration for air purification and keeping workers safe from dangerous contaminants, Ruwac's HEPA Maxx is your easy-to-install solution that takes it to the extreme. Ruwac already builds all of its industrial portable vacuum cleaners using our innovative MicroClean primary filter. At 99.9% efficient @ 0.5 microns, very few particles get past the initial filtering process, but with the HEPA Maxx's MERV 18 at 99.997% at 0.3 micron rating, clean air return is practically guaranteed while helping reduce the need for expensive primary filter replacements.

#35192 / 35193 Features

- MERV 18 at 99.997% @ 0.3 microns
- Modular construction makes them easy to install and upgrade on any WNS, WS, DS1 or Alternative Power Series vacuum
- Finite filtering purifies air
- Individually DOP certified
- Minihelic filter monitoring
- Oversized filter and housing with velocity reduction chamber
- Bottom seal positive gasket
- Average HEPA Maxx lifespan: 5 - 7 years (w/ the use of Ruwac's MicroClean primary filter)

